

Amendment number	The revised notes	DATE	SIGN	Proofread
------------------	-------------------	------	------	-----------

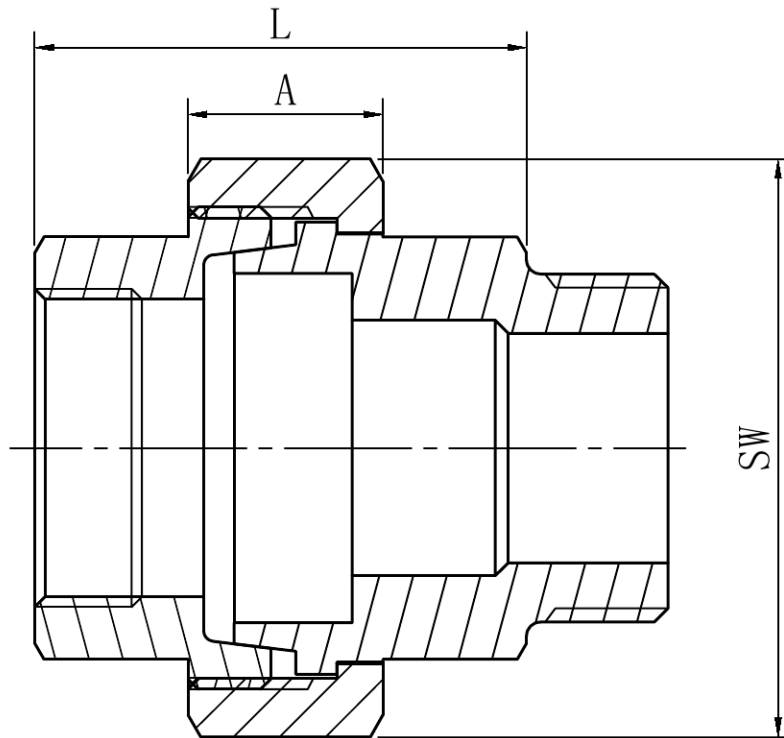

CU-Z M/F	1/8"	1/4"	3/8"	1/2"	3/4"	1"	1-1/4"	1-1/2"	2"	2-1/2"	3"	4"
L	41.0	43.0	46.0	50.5	53.0	64.0	71.0	75.0	81.0	98.0	109.0	105.0
SW	24.6	29.5	33.5	36.7	45.5	53.5	65.2	71.0	85.2	105.0	119.5	146.2
A	12.0	13.5	14.0	14.0	15.0	16.8	17.8	20.0	21.0	28.0	29.5	33.5

Technical Requirements:

- 1: When the pipe material is processed, the product should be shot blasting and pickling before processing
- 2: The surface of the parts should not have scratches, bruises and other damage to the surface defects of the parts.
- 3: Remove Burr edges.
- 4: Unmarked rounded corners $R \leq 0.5$.
- 5: Use ISO 2768-m for unspecified tolerances.

Tolerance standards: ISO 2768 (GB/T 1804-200)											BY-CU-Z M/F
Nominal Dimension	0.5~3	>3~6	>6~30							CU-Z M/F	A/0
Tolerances	±0.1	±0.1	±0.2								BY-C-001
Nominal Dimension	>30~120	>120~400	>400~1000								
Tolerances	±0.3	±0.5	±0.8						1	1	